

# CLARKE®

## POWER

## DUAL FUEL



WARNING: Do not use the generator without reading this manual

## DUAL FUEL INVERTER GENERATOR

MODEL NO: DFI1950

PART NO: 8877136

## OPERATION & MAINTENANCE INSTRUCTIONS

UK  
CA | CE



ORIGINAL INSTRUCTIONS

DL0226 - Rev 1

---

## **INTRODUCTION**

---

Before you use this product, read this manual and follow the instructions carefully. In doing so you will ensure the safety of yourself and others around you, and you can also expect your purchase to give you a long and satisfactory service.

---

## **GUARANTEE**

---

This product is guaranteed against faulty manufacture for a period of 12 months from the date of purchase. Please keep your receipt which will be required as proof of purchase.

This guarantee is invalid if the product is tampered with in any way, or not used for the purpose for which it was intended.

Faulty goods should be returned to their place of purchase, no product can be returned to us without prior permission. This guarantee does not effect your statutory rights.

---

## **UNPACKING AND ASSEMBLY**

---

Unpack your generator and check the following items are present. Should there be any missing or damaged during transit contact your CLARKE dealer.

1 x Dual Fuel Inverter Generator	1 x 12 Volt Crocodile Clip Lead Assembly
1 x Spark Plug Box Spanner with Lever Arm	1 x LPG Gas Pipe with Regulator & Pressure Reducing Valve
1 x Dual Head Screwdriver	1 x Oil Funnel
1 x Tool Bag	

## SPECIFICATIONS - DFI1950

Engine	Engine Model/Type	SC80-1/SC80L Dual Fuel
	Displacement (cc)/RPM	79.8/5500
	Ignition type	Spark Ignition
	Fuel tank capacity (L) (Safe Limit)	4.1
	Fuel Consumption at 3/4 Load (L/h / kg/h)	0.86/0.63
	Maximum run time at 3/4 load (h)	Approx. 4h 45m / 5h
	Engine oil capacity (L)	0.38
	Emissions (g/kWh) CO, HC, NOx	373.77, 8.72, 2.74
	Sound Pressure Level (LpA dB)	71.26
	Sound Power Level (LwA dB)	91.8
	Guaranteed sound power (LwA dB)	95
	Uncertainty Factor K (dB)	2.16
Generator	Rated Frequency (Hz)	50
	Rated AC Voltage per socket x 2 (V), 13 (A)	230
	Rated DC Voltage per socket x 1 (V)	12
	Rated DC Voltage per socket 1 x USB, 1 x Type C (V)	5
	Rated Output Current Petrol/LPG (A)	7.8/6.9
	Maximum Rated Output Current Petrol/LPG (A)	8.0/7.2
	Rated Output Power Petrol/LPG: (Continuous) (W)	1800/1600
	Max. Rated Output Power Petrol/LPG (W)	1850/1650
	Output Type	Sine Wave
	Starter Type	Recoil
	Operating Temperatures	-5°C to 40°C
	IP Rating	IP23

Dimensions	Depth x Width x Height (mm)	300 x 530 x 500
	Unpacked & Unfueled Weight (kg)	23.7

---

## GENERAL SAFETY RULES

---



**WARNING: EXHAUST FUMES CAN BE EXTREMELY DANGEROUS IF INHALED, DO NOT USE INDOORS.**

---

### WORK AREA

1. **ALWAYS** use in a well ventilated outdoor area. **NEVER** use indoors
2. **ALWAYS** position the exhaust outlet away from people.
3. Read these safety instructions before using the equipment.
4. Keep children away from the generator.

### POSITIONING THE GENERATOR

1. **NEVER** use inside, even if doors and windows are open. Only use outside and far away from windows, doors and vents.
2. Keep the generator at least 1 m (3 ft.) from buildings or other equipment, or the engine may overheat.
3. Place the generator on a solid, flat surface.
4. Make sure the surrounding area is free from any material that could burn or be damaged by heat.
5. **NEVER** move or tilt the generator whilst it is switched on.

### FIRE PREVENTION

1. **ALWAYS** switch the engine OFF when refuelling the petrol tank.
2. **ALWAYS** refuel in a well ventilated area.
3. **NEVER** overfill the petrol tank, only fill to the level specified.
4. **NEVER** smoke whilst refuelling and avoid smoking or using a naked flame near the generator.
5. **NEVER** start the engine if there is spilled petrol. Any spillage must be wiped clean and the generator allowed to dry before attempting to start the engine.

## **GAS SAFETY**

1. **ALWAYS** switch the engine OFF when changing the gas bottle.
2. Use **ONLY** LPG/Butane gas. Ensure the gas bottle is correctly installed and check for leaks following replacement, using soapy water. **NEVER** use a naked flame to test for leaks.
3. **ALWAYS** ensure all gas hose and regulator connections are GAS TIGHT, and the hose is not kinked or split.
4. **NEVER** store gas cylinders any closer than 2m from open drains, gullies or openings to cellars. LPG is heavier than air and can collect at low levels.
5. **NEVER** site the gas bottle next to or near the engine muffler/exhaust.
6. **ALWAYS** make sure the regulator is suitable for LPG/Butane gas.
7. **ALWAYS** make sure the regulator is suitable for the gas pressure inside the gas bottle.
8. **NEVER** use a damaged regulator.

## **PREVENTION OF ELECTRIC SHOCK**











1. **NEVER** use the generator in the rain or wet conditions unless it is well protected/under cover. Under these conditions, adequate ventilation **MUST** be provided.
2. **NEVER** operate the generator with wet hands.
3. **NEVER** use water or any other liquids to clean the generator.
4. Make sure you ground (earth) the generator (See pages 11).

## **ADDITIONAL SAFETY RULES FOR GENERATORS**

1. **ALWAYS** make sure the applied load does not exceed the generator rating. Overloading the generator is dangerous and could cause serious damage.
2. **ALWAYS** disconnect the generator when carrying out any maintenance.
3. **ALWAYS** allow the generator to reach operating speed before connecting a load.
4. **NEVER** allow the generator to run out of fuel when a load is connected.
5. **NEVER** transport the generator with fuel in the tank or gas bottle connected.
6. **NEVER** connect the generator to a commercial or residential power supply; e.g. ring main.
7. **NEVER** allow the generator air vents to become blocked.
8. **NEVER** directly cover the generator while in use.

# SYMBOLS

The following safety symbols are shown on the product or it's packaging. Please read all of the safety and operating instructions carefully before using this product.

	<b>Read instruction manual before use.</b>		<b>Hot surfaces - DO NOT TOUCH.</b>
	<b>Dangerous Voltage - Risk of Electrocution.</b>		<b>Poisonous fumes - DO NOT USE the generator in an enclosed space.</b>
	<b>Fire Hazard. Fuel and vapours are extremely flammable and explosive.</b>		<b>Caution - The user should be aware of a general hazard.</b>
	<b>DO NOT USE indoors.</b>		<b>DO NOT USE in the rain or snow.</b>
	<b>DO NOT directly cover the generator while in use.</b>		<b>Caution - Loud noise when in use.</b>

---

## GENERATOR LOCATION

---



**WARNING: EXHAUST HEAT/GASES CAN IGNITE COMBUSTIBLES, STRUCTURES OR DAMAGE THE FUEL TANK, CAUSING A FIRE. KEEP AT LEAST 5FT (1.5M) CLEARANCE ON ALL SIDES OF THE GENERATOR INCLUDING OVERHEAD.**

---

Place the generator in a well ventilated area. This will allow for removal of deadly exhaust gas. **DO NOT** place the generator where gas could accumulate and enter inside or be drawn into a potentially occupied building. Ensure exhaust gas (A) is kept away from any windows, doors, ventilation intakes, or other openings that can allow exhaust gas to collect in a confined area. Prevailing winds and air currents should be taken into account.

---



**WARNING: OPERATE THE GENERATOR ONLY OUTDOORS. DO NOT START OR RUN THE ENGINE INDOORS OR IN ENCLOSED AREAS, EVEN IF WINDOWS AND DOORS ARE OPEN.**

---

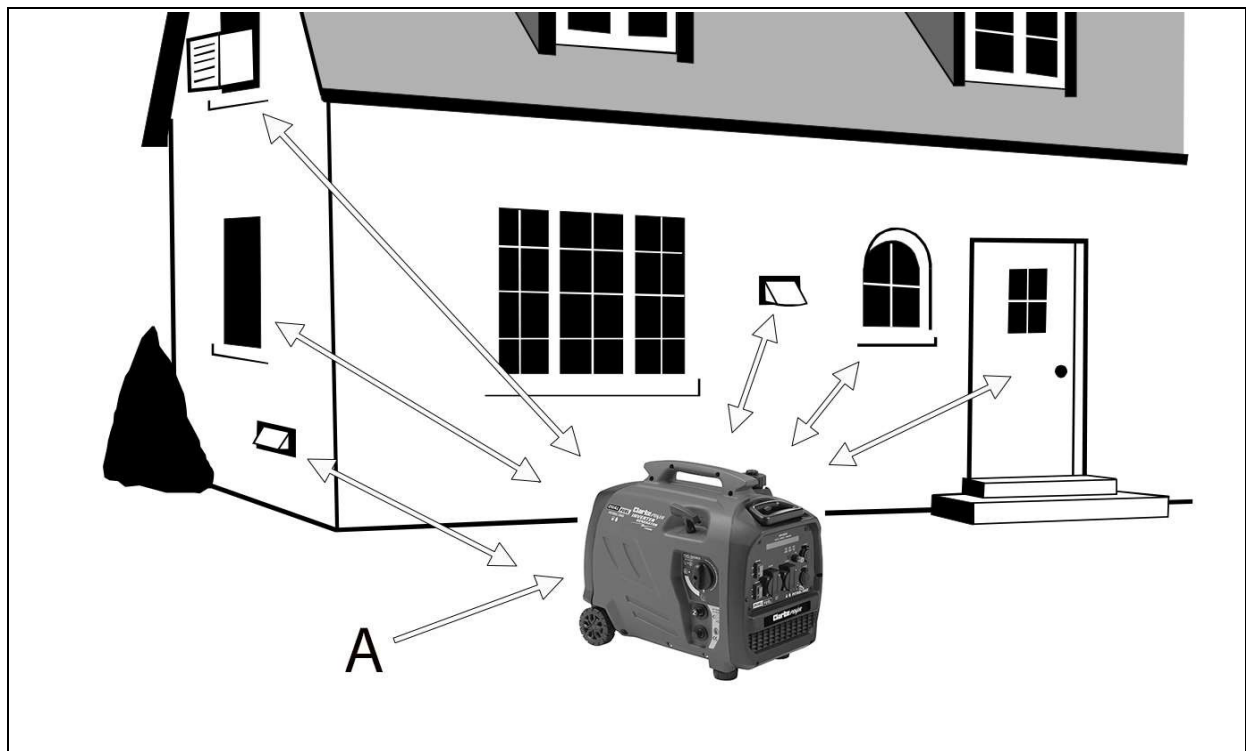

# GENERATOR OVERVIEW - CONTROL PANEL



NO	DESCRIPTION	NO	DESCRIPTION
1	Data Centre: Petrol Fuel Level, Time Running, Total Time Running, Voltage, Frequency and Load (kW)	6	230V 3 Pin AC Outlet (IP54 Rated)
2	LED Indicators: Output Indication, Overload Alarm and Low Oil Alert	7	12V Cigarette Lighter DC Outlet
3	Main Switch	8	DC Reset Button
4	Low Idle Switch	9	5V DC USB & Type 'C 'Outlets
5	230V 3 Pin AC Outlet (IP54 Rated)	10	Earthing Connection Point

# GENERATOR OVERVIEW - GENERAL



NO	DESCRIPTION	NO	DESCRIPTION
1	Retractable Handle	5	Recoil Pull Handle
2	Fuel Filler Cap	6	Fuel Source Switch
3	Spark Plug Cover	7	Choke Lever
4	Main Maintenance Cover	8	LPG Gas Inlet

# CONTROL FUNCTIONS

## LOW IDLE

When the Low Idle switch is in the 'ON' position the throttle controls the engine speed according to the connected electrical load. The results are better fuel consumption and less noise. When the switch is in the 'OFF' position the engine runs at 4500 rpm regardless of the electrical load.

**NOTE:** The Low Idle switch must be in the 'OFF' position when using electrical devices that require a large starting current, such as a compressor, pump or refrigerator.



## LED INDICATORS

The LED indicators assist in communicating status and functions of the unit.

1. **Output Indicator (Green):** The output indicator comes on when the engine starts and produces power.
2. **Overload Alarm (Red):** The overload alarm comes on when a connected device requires more power than the generator is able to produce. The output indicator will go off and the overload alarm will stay on, but the engine will continue to run.



### **NOTE: DO NOT OVERLOAD THE GENERATOR**

3. **Low Oil Alarm (Red):** The the engine oil falls below the required level the low oil alarm will come on and the engine will stop automatically. The engine will not restart until oil is added to the unit to bring it up to the appropriate level.

---

## BEFORE USING THE GENERATOR

---

Before using your generator check that:

- The generator is in good condition and free from any damage.
- The generator is clean and free from fuel or oil spillage.
- There are no leakages on the LPG pipe and regulator.
- The generator is correctly located for use (see page 4).

**NOTE:** To avoid accidental spillage of fuel, use a funnel to fill the fuel tank. If fuel is spilled it must be removed from the unit before attempting to start the engine.

## EARTHING

---



**WARNING: GENERATORS SHOULD ALWAYS BE EARTHED. IT IS ADVISABLE TO PROPERLY EARTH YOUR GENERATOR BEFORE STARTING, USING A WIRE AND A SMALL METAL EARTH SPIKE. THE WIRE AND EARTH SPIKE ARE NOT SUPPLIED WITH THIS UNIT.**

---

An earth rod and cable can be purchased at your local camping or electrical supplier, or alternatively an earth rod can be made and it is suggested you get advice from a qualified electrician.

The cable used should be insulated and a maximum length of 1 metre and a minimum of 1.0mm<sup>2</sup> to carry a 13amp load.

Attach the cable to the generator at the earthing point (shown on the right).

Connect the other end of the cable to a steel or copper earth rod, making sure you connect it in accordance with the installation instructions supplied with the rod.

When pushing the rod into the ground the generator must not be running and it is suggested that the rod is pushed into the ground by at least 100 mm.



Earthing of generators is covered in BS7430:2011. If you have any doubts about this subject consult a qualified electrician.

## CHECKING & ADDING ENGINE OIL

**NOTE:** The generator has been shipped without engine oil. **ALWAYS** add oil before starting for the first time.

**NOTE:** If the oil level is low, the Low Oil Alert indicator will illuminate, see page 8.

1. Place the generator on a level surface and check the oil level as follows.

**NOTE:** The oil reservoir capacity is 380mm

2. Remove the maintenance cover located on the side of the generator, by unscrewing the large knob and pulling the cover off.



3. Turn the oil filler cap anti-clockwise and remove from the oil reservoir, wipe the dipstick with a clean cloth.
4. Insert the dipstick back into the oil filler tube and then remove it again.

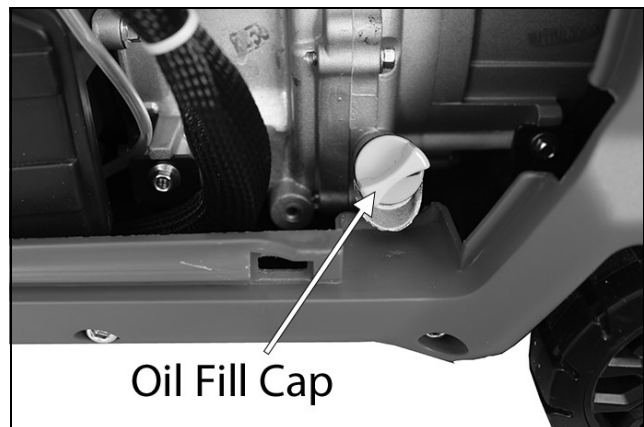

5. If the oil is below the Min. level on the dipstick, top up the oil reservoir with fresh oil using the oil funnel.

- **DO NOT** fill above the max level mark.
- We recommend the use of SAE10W-30 oil in this generator. (CLARKE part number 3050845)
- **DO NOT** tilt the generator when adding engine oil. This could result in overfilling and damage to the engine.

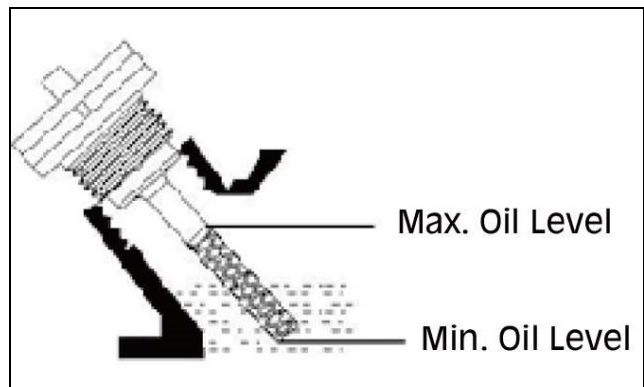

6. Replace the oil filler cap.
7. Replace the maintenance panel.

## CHECKING & ADDING PETROL FUEL



**WARNING: MAKE SURE THERE IS FUEL IN THE TANK WHEN USING THE GENERATOR. RUNNING OUT OF FUEL OR STOPPING THE ENGINE SUDDENLY WITH A LOAD CONNECTED COULD CAUSE SERIOUS DAMAGE.**

**WARNING: FUEL IS HIGHLY FLAMMABLE AND POISONOUS.**

**WARNING: SEE GENERAL SAFETY RULES ON PAGE 4 AND READ THEM CAREFULLY BEFORE REFUELING.**

**WARNING: DO NOT FILL ABOVE THE RED MARKER IN THE FUEL FILTER OR IT MAY OVERFLOW WHEN THE FUEL HEATS UP AND EXPANDS.**

**WARNING: WIPE UP ANY SPILLED FUEL IMMEDIATELY.**

**WARNING: AFTER REFUELING, MAKE SURE THE FUEL FILLER CAP IS TIGHTENED SECURELY.**

### RECOMMENDED FUEL

Your generator has been designed to use regular unleaded petrol with a octane number of 85 or higher.

**NOTE: DO NOT** mix oil with the fuel.

**NOTE:** The data centre display will highlight the petrol fuel level in the tank.

**NOTE:** The fuel tank capacity is 4.1 litres (Safe Fuel Level).

1. Remove the fuel filler cap located on top of the generator.
2. Make sure the fuel filter is in place.
3. Slowly add fuel to the fuel tank.
4. **DO NOT** fill above the red marker located in the fuel filter.
5. Replace the fuel filler cap securely.

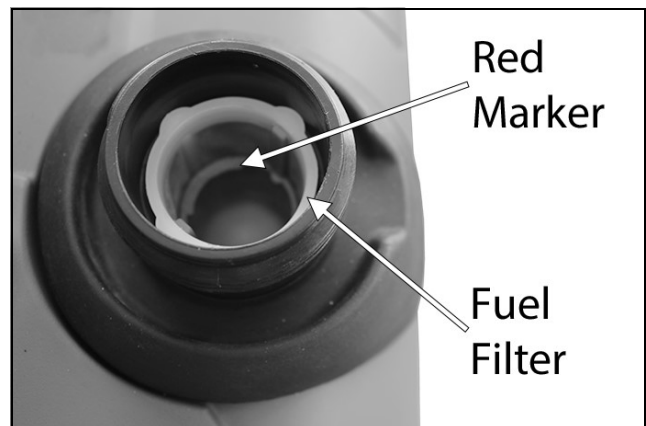
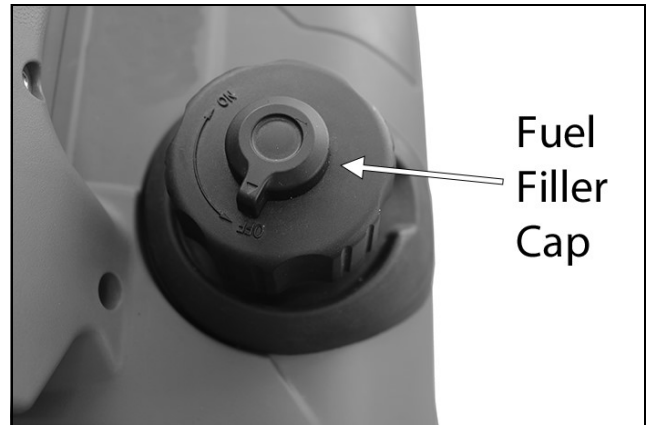

# USING YOUR GENERATOR

**WARNING: OPERATE THE GENERATOR IN A WELL VENTILATED AREA OUTSIDE.**

**NOTE: DO NOT** connect any electrical devices to the outlets on the generator before starting the engine.

## STARTING THE ENGINE USING PETROL FUEL SOURCE

1. Check that the generator is correctly earthed, see page 11
2. Turn the FUEL SOURCE switch to the 'PETROL' position.



3. Set the LOW IDLE switch to the 'OFF' position.



4. Set the MAIN switch to the 'ON' position.



5. While holding the fuel filler cap so that it will not move, turn the AIR VENT knob to the 'ON' position.

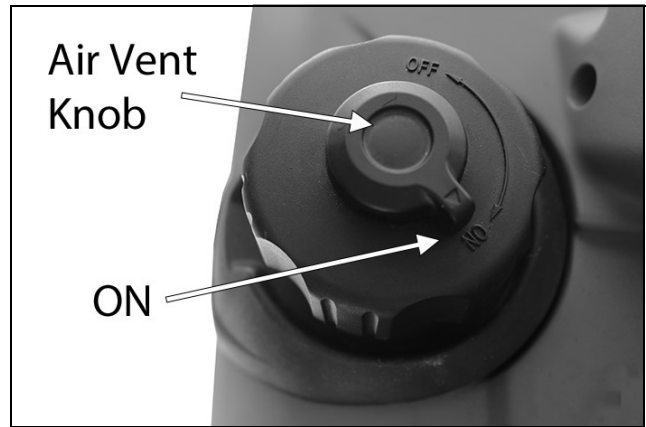

6. Pull the CHOKE LEVER out to the 'START' position.

**NOTE:** Skip this if starting the generator with a warm engine and leave the CHOKE LEVER in the 'RUN' position.

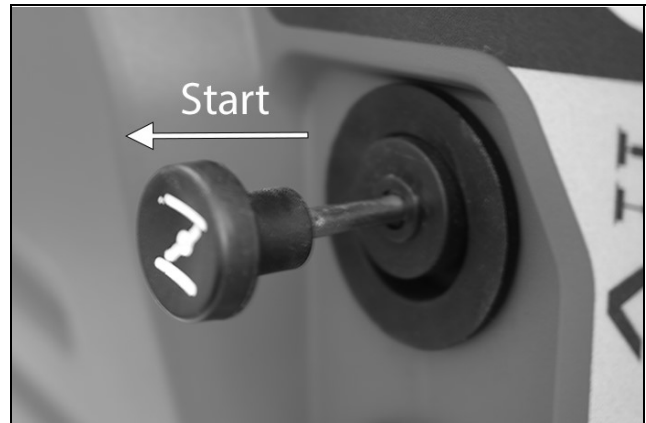

7. Place one hand on the generator to hold it in place and pull on the recoil starter handle slowly until a slight resistance is felt. Then pull quickly to start the engine. Return the handle gently into the machine. **NEVER** allow the handle to snap back.

**NOTE:** If you have repeated failed attempts to start the engine, please consult the troubleshooting section on pages 32-33.

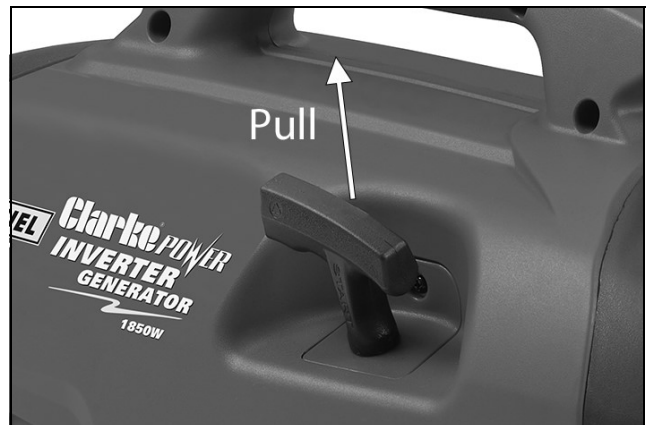

8. Allow the generator to run for several minutes before attempting to connect any electrical devices. This allows the generator to stabilize its speed and temperature.

9. Once the speed and temperature has stabilized, push the CHOKE LEVER back in to the 'RUN' position.

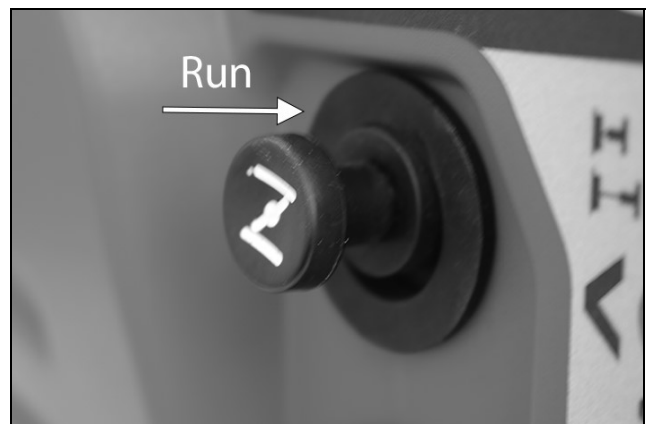

## STARTING THE ENGINE USING LPG GAS FUEL SOURCE

1. Check that the generator is correctly earthed, see page 11
2. Turn the FUEL SOURCE switch to the 'LPG' position.



3. Connect the LPG gas hose to the propane gas fuel source.

**NOTE:** Make sure the gas bottle is upright and on a flat level surface.

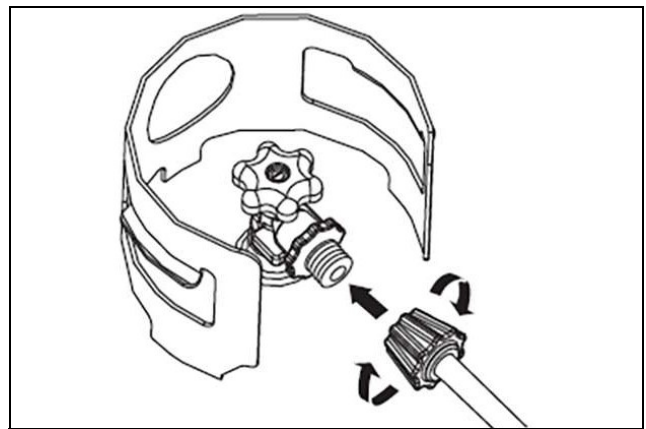

4. Connect the small end of the LPG gas hose to the LPG inlet on the generator. Tighten the connection using a size 19 (3/4") spanner to prevent leakage.

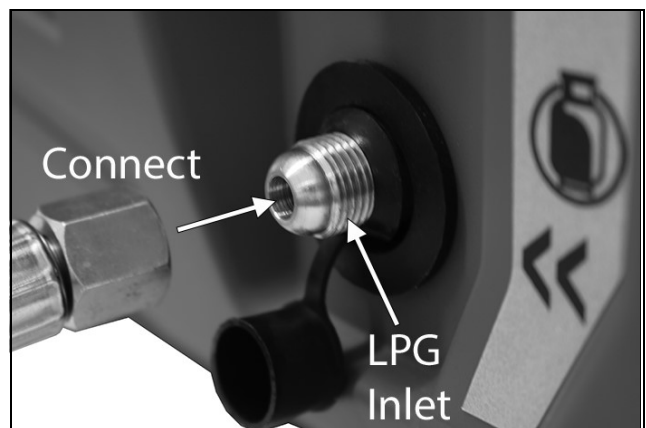

5. Set the LOW IDLE switch to the 'OFF' position.



6. Set the MAIN switch to the 'ON' position.

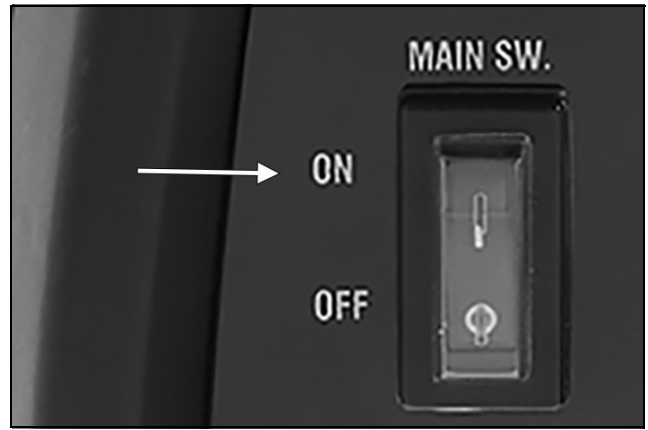

7. Rotate the LPG gas bottle valve fully to the 'OPEN' position.

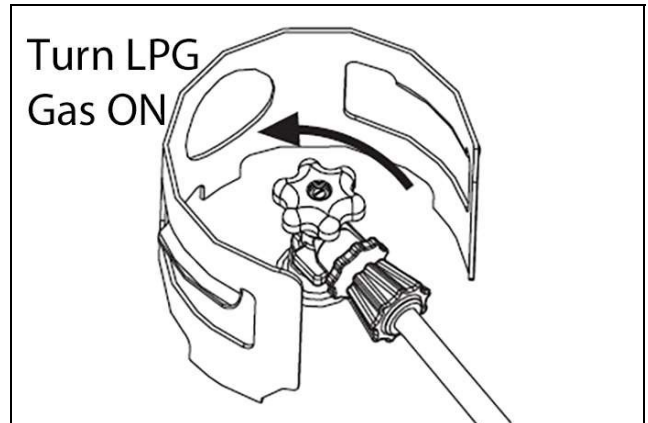

8. With the CHOKE LEVER in the 'RUN' position, press and hold the PRESSURE REDUCING VALVE BUTTON for 3-4 seconds to store air.

**NOTE:** Skip this if starting the generator with a warm engine and leave the CHOKE LEVER in the 'RUN' position.

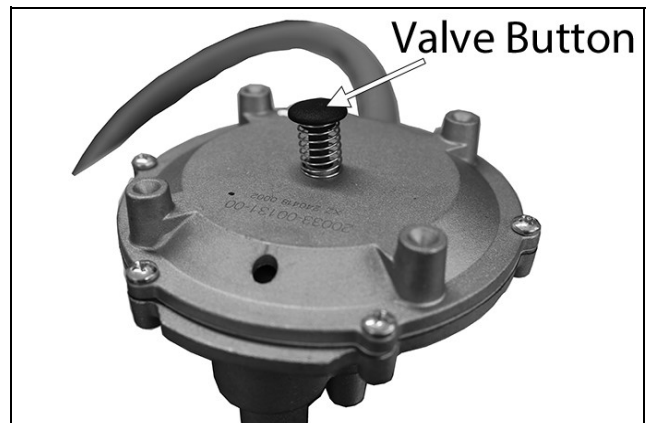

9. Place one hand on the generator to hold it in place, and pull on the recoil starter handle slowly until a slight resistance is felt. Then pull quickly to start the engine. Return the handle gently into the machine. **NEVER** allow the handle to snap back.

**NOTE:** If you have repeated failed attempts to start the engine, please consult the troubleshooting section on pages 30-31

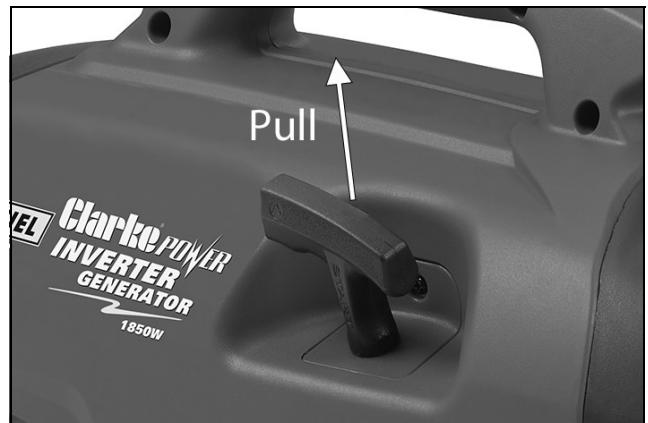

10. Allow the generator to run for several minutes before attempting to connect any electrical devices. This allows the generator to stabilize its speed and temperature.

## SHUTTING DOWN THE GENERATOR

1. Turn off and disconnect any electric devices that are attached to the generator.
2. Turn the MAIN switch to the "OFF" position.



3. While holding the fuel filler cap so that it will not move, turn the AIR VENT knob to the 'OFF' position.

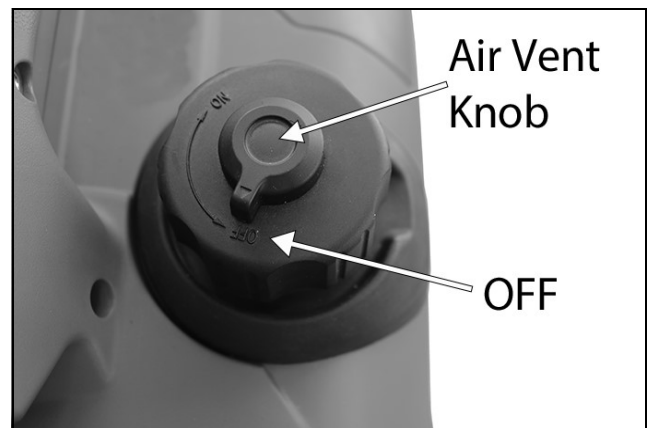

**CAUTION: ALLOW THE GENERATOR TO COOL FOR SEVERAL MINUTES BEFORE TOUCHING AREAS THAT BECOME HOT DURING USE.**

## CONNECTING ELECTRICAL DEVICES

The generator can supply both 230V AC and 5V USB & 12V DC.

**NOTE:** Make sure the generators rated voltage and amperage capacity is adequate to supply all the electrical loads that the unit will power, see specification section on page 3.

### AC POWER

1. Start the engine. See pages 14-17.
2. Make sure the appliance is turned off before connecting it to the generator.
3. Connect the appliance to the generator using one of the two 3 Pin 13A 230V AC outlets.



**CAUTION: MAKE SURE THAT THE APPLIANCE BEING CONNECTED IS IN GOOD WORKING ORDER, IF IT BEGINS TO ACT ABNORMALLY OR STOPS SUDDENLY, DISCONNECT IT FROM THE GENERATOR**

**CAUTION: MAKE SURE THE APPLIANCE DOES NOT EXCEED THE MAXIMUM RATED LOAD FOR THE GENERATOR.**

**CAUTION: ANY DEVICE WHICH CONTAINS AN INDUCTIVE LOAD E.G. DEVICES THAT CONTAIN A MOTOR MAY REQUIRE MORE CURRENT ON STARTUP.**

### DC & USB POWER

1. Start the generator. See pages 14-17.
2. Make sure the appliance is turned off before connecting it to the generator.
3. Connect the
  - 12V appliance (max 9A) to the generator via the 12V cigarette lighter socket.

**NOTE:** If the 12V socket overloads, disconnect the device and press the reset button.

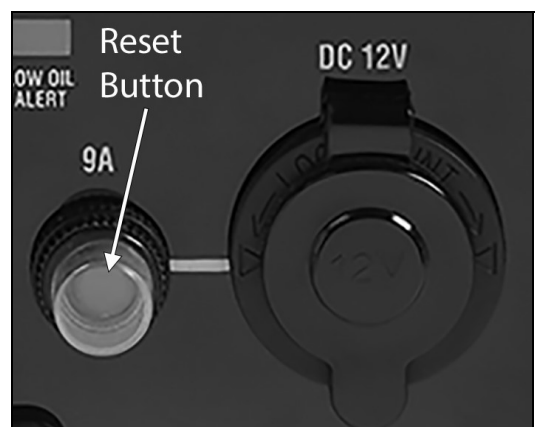

- 5V appliance to the generator via the USB or Type 'C' connection sockets.



## **POWER MANAGEMENT/WATTAGE USE**

Follow these simple steps to calculate the running and starting watts necessary for your purposes.

### **CAPACITY**

1. Select the electrical devices you plan on running at the same time.
2. Total the running watts of these items. This is the amount of power you need to keep your items running.
3. Identify the highest starting wattage of all devices identified in step 1.
  - Add this number to the number calculated in step 2.
  - Surge wattage is the extra burst of power needed to start some electrical driven equipment. Following the steps listed under the following section (Power Management) will guarantee that only one device will be starting at a time.

### **POWER MANAGEMENT**

Use this formula to convert voltage and amperage to watts: Volts x Amps = Watts

To prolong the life of your generator and attached devices, follow these steps to add electrical loads.

1. Start the generator with no electrical load attached, see pages 12-16.
2. Allow the engine to run for several minutes to stabilize.
3. Plug in and turn on the first item. It is best to attach the item with the largest load first.
4. Allow the engine to stabilize.
5. Plug in and turn on the next item.
6. Allow the engine to stabilize.
7. Repeat steps 5 & 6 for each additional item.

## WATTAGE REFERENCE GUIDE

These are estimates only. Check your appliance or tool for exact wattage requirements. The wattage listed are based on estimated wattage requirements.

For exact wattages, check the data plate or owners manual for the item you wish to power.

Operating voltage and frequency requirements of all electronic equipment should be checked prior to plugging them into the generator. Damage may result if the equipment is not designed to operate within +/- 10% voltage variation and +/- 3 Hz frequency variation from the generator specification ratings, see Specification section on page 3.

ITEM	RUNNING WATTS	STARTING WATTS
Light Bulb	100	100
Refrigerator/Freezer	1200	2400
Sump Pump	600	1800
Well Pump 1HP	2000	4000
Water Heater	4000	-
Security System	180	-
AM/FM Radio	300	-
Battery Charger 12V	110	-
Fan	300	600
Microwave	1000	-
27" Television	500	-
Computer with Monitor	800	-
Belt Sander	1000	1500
Bench Grinder	700	1500
Circular Saw	1500	1500
Compressor 1.5 HP	1000	1000
Power Drill	1000	1000
Paint Sprayer	600	1200
Table Saw	2000	2000

## DC POWER (TOPPING UP CAR BATTERIES)



**WARNING: FOR YOUR SAFETY PERFORM THE FOLLOWING INSTRUCTIONS IN THE ORDER SHOWN.**

**WARNING: YOU SHOULD ONLY USE THIS GENERATOR TO 'TOP UP' THE BATTERY AS TRYING TO CHARGE A COMPLETELY FLAT BATTERY MAY CAUSE THE FUSE TO BLOW.**

1. Set the LOW IDLE Switch to the 'OFF' position.
2. Start the generator. See pages 12-16.
3. Connect the battery charging leads to the battery.
  - Make sure you clamp the red wire to the positive (+) terminal and the black wire to the negative (-) terminal of the battery.



4. Connect the battery charging lead to the generators 12V cigarette lighter socket.
  - The battery will begin to charge
5. Monitor the voltage across the battery regularly during charging and disconnect the battery when the voltage reaches 14.4 volts.

**NOTE: ALWAYS** refer to the battery manufacturer to determine charging times.



**CAUTION: WHEN DISCONNECTING THE BATTERY, ALWAYS DISCONNECT THE NEGATIVE LEAD FIRST.**

**CAUTION: DO NOT ALLOW THE RED AND BLACK CLAMPS TO TOUCH WHILE STILL CONNECTED TO THE GENERATOR.**

### DC OVER LOAD PROTECTOR

If the overload protector activates, wait for a few minutes and then press the reset button.



# MAINTENANCE

Some adjustments will need to be made periodically to properly maintain the generator. All service and adjustments should be made at least one time every year. It is important that the maintenance chart below is followed:

Item	Action	Frequency			
		Each Time of Use	Every 3 Months or 50 Hrs	Every 6 Months or 100 Hrs	Every Year or 300 Hrs
Engine Oil (Page 25-26)	Check Level	*			
	Replace			*	
Air Filter (Page 27)	Check	*			
	Clean		**		
	Replace				*
Spark Plug (Page 24-25)	Clean - Adjust			****	
	Replace				*
Spark Arrestor (Page 29-30)	Clean			*	
Idling	Check - Adjust				***
Valve Clearance	Check - Adjust				***
Fuel Tank	Clean				***
Fuel Filter (page 28)	Check - Clean		*		
Fuel Supply Line	Check	Every Two Years (Replace if Necessary***)			

- \*\* = Recommended to be performed more often than in the schedule if operated in a dusty environment.
- \*\*\* = Recommended to be performed by a CLARKE authorized dealer.
- \*\*\*\* = Adjust air gap to 0.6 - 0.7 mm.

## CHANGING SPARK PLUG



**CAUTION: ALLOW THE ENGINE TO COOL BEFORE REMOVING THE SPARK PLUG.**

### SPARK PLUG INSPECTION

The spark plug is an important engine component and should be checked periodically.

1. Remove the spark plug cover panel located on top of the generator by sliding it out.

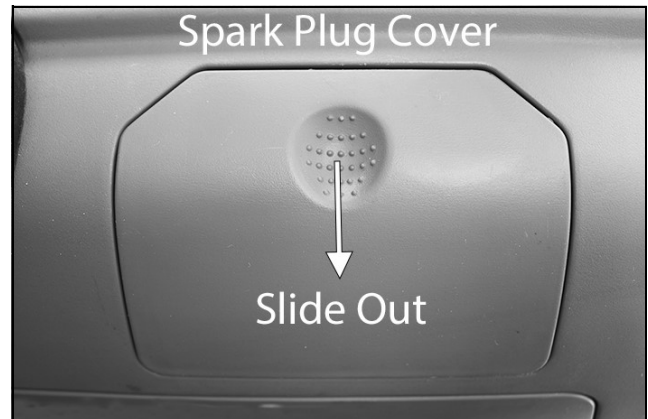

2. Remove the spark plug cap from the spark plug.

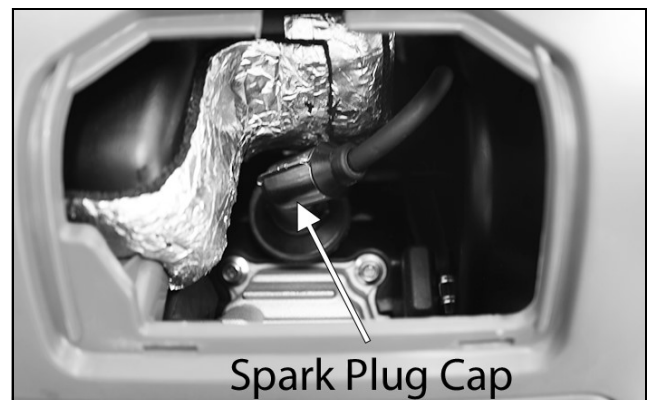

3. Fit the spark plug box spanner over the spark plug as shown. Turn the spanner counterclockwise to remove the spark plug.

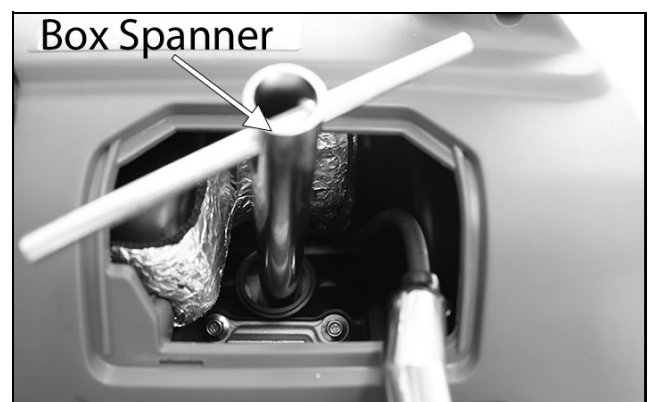

4. When the spark plug has been removed, check for discoloration and use a wire brush to remove any carbon build up.

**NOTE:** The carbon porcelain insulator around the centre electrode of the spark plug should be a medium to light tan colour.

5. Check the spark plug gap (a) with a feeler gauge, it should be between 0.6 and 0.7 mm.

- Adjust if necessary.

6. Check the overall condition of the spark plug and replace if damaged.

**NOTE:** Spark plugs are available from CLARKE Spare Parts department 020 8988 7400.

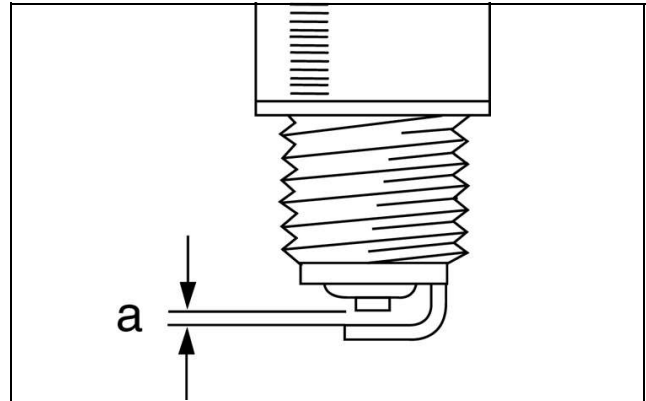

7. Reinstall the spark plug and replace the spark plug cap and cover panel.

**NOTE:** Spark Plug Information

- Spark Plug Type: E5T (E5RTC) or equivalent
- Spark Plug Gap: 0.6-0.7mm (0.024-0.028in)
- Spark Plug Torque: 20.0 N/m (2.0kgf/m, 14.8lb/ft)

## CHANGING ENGINE OIL



**CAUTION: PROLONGED EXPOSURE TO USED ENGINE OIL IS DANGEROUS, ALWAYS WASH YOUR HANDS THOROUGHLY AFTER HANDLING USED ENGINE OIL.**

Initial replacement of the engine oil is after one month or 20 hours of operation, whichever ever comes first.

1. Place the generator on a level surface and warm up the engine for several minutes. Then stop the engine and turn the main switch to 'OFF' and the fuel cap air vent to 'OFF'.
2. Unscrew the main fixing screw and remove the maintenance panel shown on the right.



3. Turn the oil filler cap anti-clockwise and remove from the oil tank.

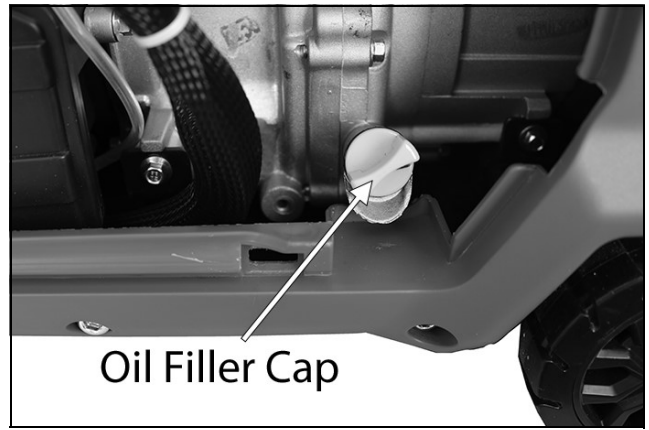

4. Place an oil pan next to the engine and tilt the generator to allow the oil to drain out of the oil reservoir into the pan via the drain channel.

**NOTE:** You may need assistance with this step as the generator is heavy.

5. Return the generator to a level surface.

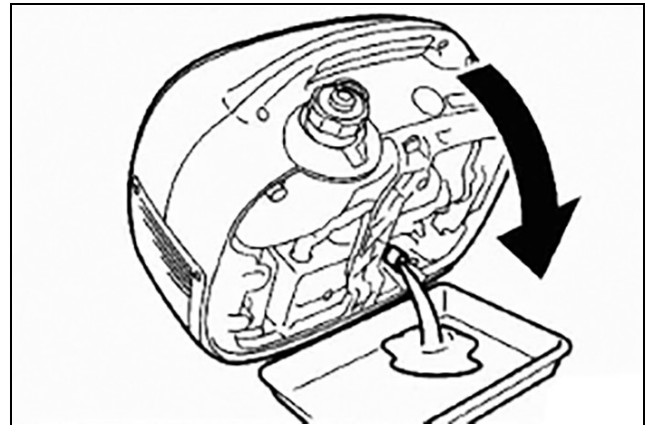

6. Fill the oil reservoir with fresh oil.

- **DO NOT** fill above the max level mark (0.4 litres)
- We recommend the use of SAE10W-30 oil in this generator. (CLARKE part number 3050845)

7. Replace the oil filler cap and maintenance panel.

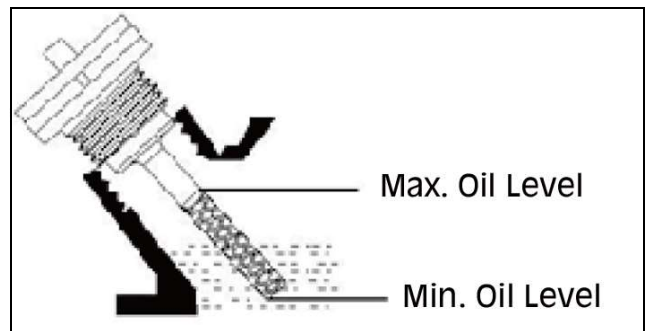

### **ENVIRONMENTAL PROTECTION**

One of the most damaging sources of pollution is oil. **DO NOT** throw away used engine oil in with your domestic waste or down drains and sinks. Place it in a leak proof container and dispose of it according to local regulations.

## CHANGING AIR FILTER



**WARNING: DO NOT USE FLAMMABLE SOLVENTS OR PETROL TO CLEAN THE AIR FILTER.**

The air filter may need to be cleaned more frequently when used in unusually wet or dusty conditions.

1. Unscrew the main fixing screw and remove the maintenance panel shown on the right.



2. Remove the air filter cover screw, shown on the right.
3. Remove the air filter cover.

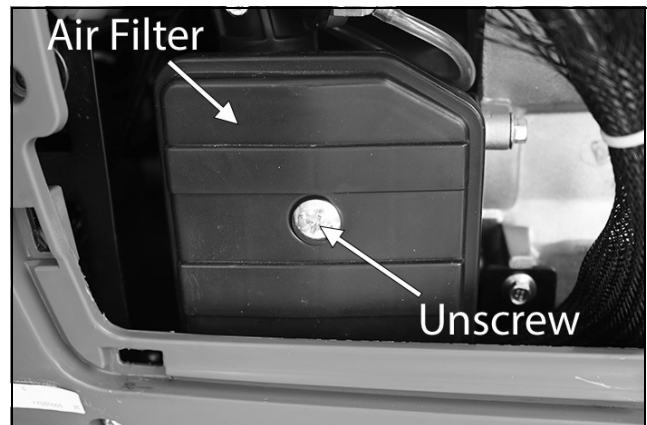

4. Remove the air filter element.
5. If the air filter is damaged contact the CLARKE spare parts department for a replacement.
  - If the filter is dirty, wash it in a solution of warm water and mild detergent and then rinse thoroughly.
  - Leave the filter to dry completely, once it is dry immerse the filter in clean engine oil and squeeze the filter to remove excess oil.
6. Replace the filter into its original position and replace and secure the air filter cover and maintenance cover.



## CLEAN FUEL TANK FILTER

Just inside the fuel filler cap is a fuel filter. Check this filter periodically and remove any contaminants which may have accumulated.

1. Remove the fuel filler cap.

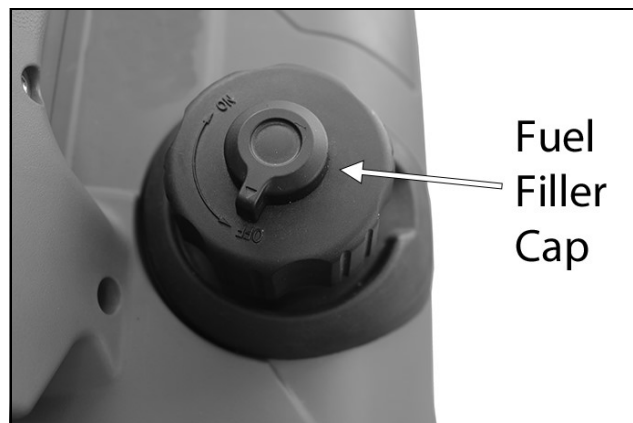

1. Lift out the filter inside.



2. Clean the filter with solvent. If the filter is damaged, contact CLARKE Spare Parts department 020 8988 7400 for a replacement.
3. Replace the filter and fuel tank cap.



**CAUTION: ALLOWING PETROL TO SIT IN THE FUEL TANK FOR LONG PERIODS OF TIME CAN MAKE IT DIFFICULT TO START THE GENERATOR IN THE FUTURE. NEVER STORE THE GENERATOR FOR EXTENDED PERIODS OF TIME WITH FUEL IN THE TANK, SEE PAGES 28-29.**

## MUFFLER SCREEN AND SPARK ARRESTOR



**CAUTION: ALLOW THE ENGINE TO COOL BEFORE REMOVING THE COVER.**

1. Remove the 6 screws holding the muffler cover in place and remove the cover.



2. Using a cross headed screwdriver and size 7 (5/16") spanner, loosen and remove the muffler clip.

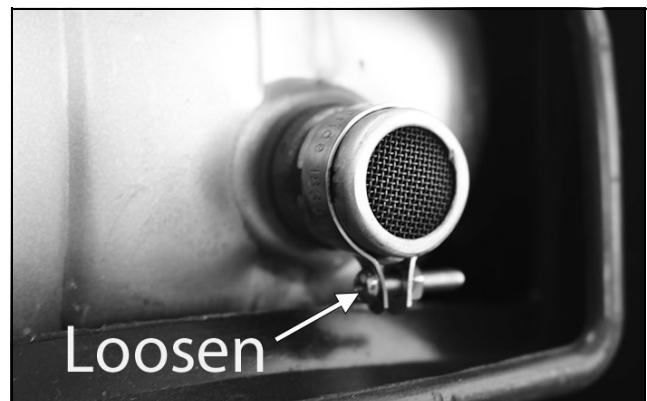

3. Using a crossed headed screwdriver, remove the grub screw from the underside of the muffler.
4. Remove the muffler and spark arrestor from the engine.

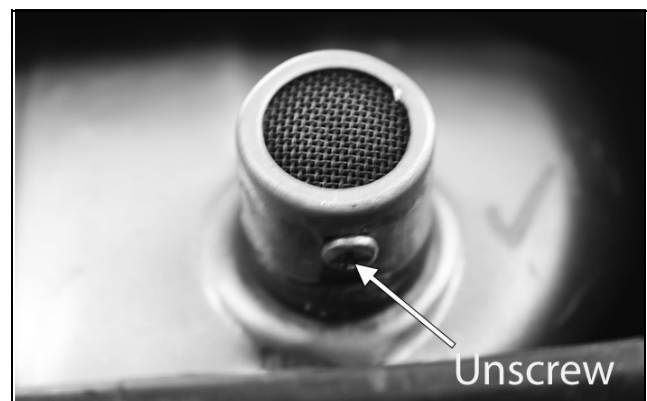

- Remove any carbon deposits from the muffler screen and spark arrestor using a wire brush. Use the wire brush lightly to avoid damaging the muffler screen and spark arrestor.
- Replace the muffler screen and spark arrestor back in position and replace the grub screw and clip.
- Replace the muffler cover.

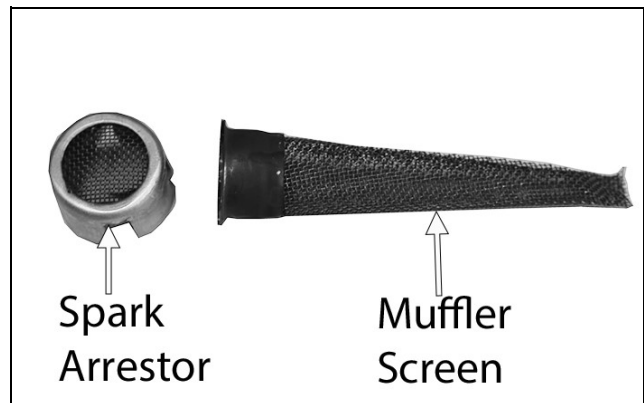

## STORAGE

Long term storage of the generator will require some preventive procedures to guard against deterioration.

### DRAIN THE FUEL & OIL

- Remove the fuel tank cap. Remove the fuel filter and extract the fuel from the tank into an approved petrol container using a commercially available hand siphon (CLARKE CSP560 Siphon Pump, part no. 6499610).
- Replace the fuel tank cap.



**CAUTION: PETROL IS HIGHLY FLAMMABLE, DO NOT PERFORM THIS MAINTENANCE WHILE SMOKING OR NEAR AN OPEN FLAME. IMMEDIATELY WIPE OFF SPILLED FUEL WITH A CLEAN, DRY, SOFT CLOTH, SINCE PETROL MAY DETERIORATE PAINTED SURFACES OR PLASTIC PARTS.**

- Start the engine (see pages 14-17) and let it run until it stops. The duration of the running of the engine depends on the amount of petrol left in the tank.
- Unscrew the main fixing screw and remove the maintenance panel.
- Drain the petrol from the carburetor by placing the drain tube into a container and loosening the drain screw on the carburetor float chamber.
- Re-tighten the drain screw.
- Remove the oil dipstick and drain the oil, see pages 25-26.
- Install the maintenance cover.
- Turn the fuel tank cap air vent knob to the 'OFF' position.

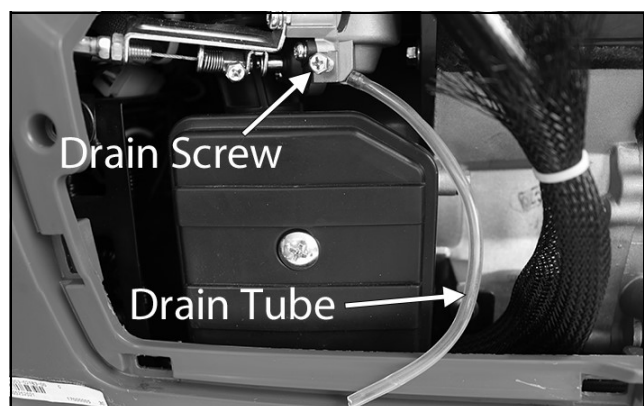

### ENGINE

Perform the following steps to protect the cylinder, piston ring, etc. from corrosion.

1. Remove the spark plug, see pages 24-25.
2. Pour about one table spoon of SAE10W-30 motor oil into the spark plug hole and reinstall the spark plug.
3. Make sure the MAIN SWITCH is in the 'OFF' position, pull the Recoil Starter Handle several times to coat the cylinder walls with oil. This will prevent the cylinder and valves from rusting.

## **STORAGE**

1. Clean any spilt petrol or oil from the outside of the generator.
2. Store the generator in a dry, well ventilated place, with a cover placed over it.
3. The generator must remain in a vertical position when stored, carried or operated.

---

## **ENVIRONMENTAL PROTECTION**

---



Recycle unwanted materials instead of disposing of them as waste. All tools, accessories and packaging should be sorted and taken to a recycling centre for disposed in a manner compatible with the environment.

By purchasing this product, the customer is taking on the obligation to deal with its safe disposal in accordance with the Waste Electrical and Electronic Equipment (WEEE).

In effect, this means that this product must not be disposed of with general household waste. It must be disposed of according to the laws governing Waste Electrical and Electronic Equipment (WEEE) at a recognised disposal facility. If disposing of this product or any damaged components, do not dispose of with general waste. This product contains valuable raw materials. Metal products should be taken to your local civic amenity site for recycling of metal products.

## **PETROL & OIL WASTE**

**NEVER** dispose of petrol or oil down a drain or sink. Collect any waste petrol and oil in a suitable container and dispose of it in accordance with your local authority regulations.

---

# MAINTENANCE RECORD

---

## ENGINE OIL

---

---

---

---

---

---

## AIR FILTER

---

---

---

---

---

---

## SPARK PLUG

---

---

---

---

---

---

## FUEL FILTER

---

---

---

---

---

---

## BI-ANNUAL SERVICE

---

---

---

---

---

---

# TROUBLESHOOTING

PROBLEM	CAUSE	SOLUTION
Engine does not start	Engine switch in OFF position	Set engine switch to CHOKE position
	Fuel tank is filled with contaminated or old fuel	Change the fuel in the tank
	Not enough oil in crankcase	Add or replace oil
	Air filter is dirty	Clean or replace air filter
	Spark plug is dirty	Clean spark plug
	Spark plug is broken	Replace spark plug
	Generator is not on level surface	Move generator to a level surface to prevent low oil shutdown from triggering
	Engine needs maintenance	Contact the CLARKE service department for more information
Engine Stops	Generator was tilted when adding oil or shipped side down	Remove spark plug, turn engine switch to the OFF position then pull recoil starter four (4) times to remove oil from the combustion chamber. Replace spark plug and restart engine
	Fuel tank vacuum relief valve on OFF position	Turn fuel tank vacuum relief valve to the ON position
	Not enough oil in crankcase	Add or change oil
Blue smoke in exhaust	Engine is out of fuel	Check fuel gauge and add fuel if needed
	Generator inclined, oil has entered combustion chamber	Move generator to a level position
	To much oil has been added to the crankcase	Drain excess oil

<b>PROBLEM</b>	<b>CAUSE</b>	<b>SOLUTION</b>
Generator runs but does not support all electrical devices connected	Bad connecting wires/cables	If using an extension cable, try a different one
	Bad electrical device connected to generator	Try connecting a different device
	Generator is overloaded, (overload light is on).	Perform these steps: 1: Turn off all electrical devices 2: Unplug all electrical devices 3: Shut down the engine 4: Wait several minutes and then restart the engine 5: Try connecting fewer electrical loads to the generator
	Short circuit in one of the connected devices	Try disconnecting any faulty or short circuited electrical loads

If this does not solve your problem, please contact the CLARKE Service Department.

# EXPLODED DIAGRAM

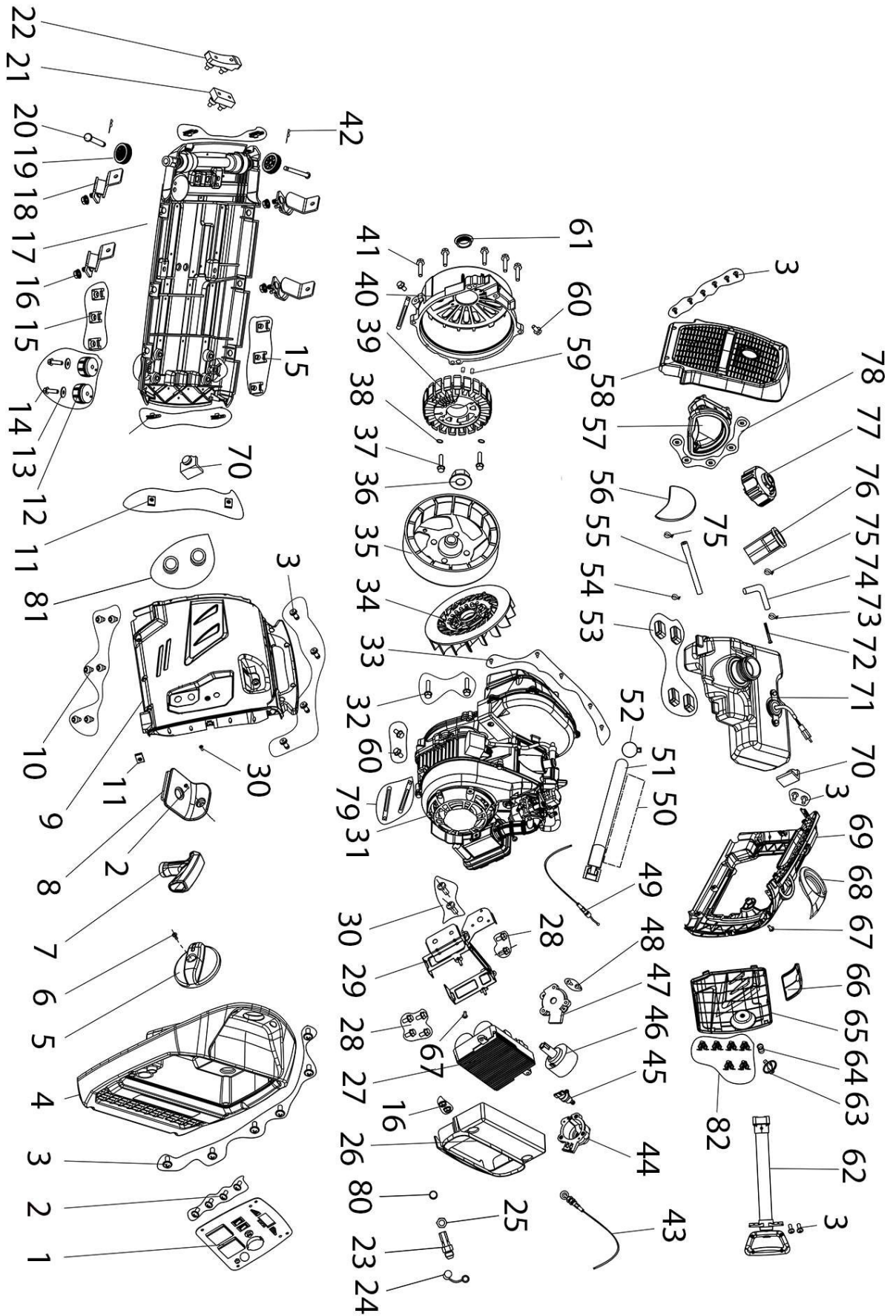

## PARTS LIST

No	Description	No	Description
1	Control Panel Assembly	22	Motor Gasket
2	Cross Recessed Pan Head Screw (x 5)	23	Dust Cap
3	Cross Recessed Pan Head Screw (x 20)	24	LPG Connecting Pipe
4	Inverter Intake Cover Assembly	25	Nut
5	Oil Switch Knob	26	Inverter Cover
6	Cross Recessed Pan Head Screw	27	Inverter Component
7	Handle Component	28	Hex Flange Bolt (x 7)
8	Handle Stopper	29	Inverter Bracket
9	Machine Front Shell Assembly	30	Cross Recessed Pan Head Screw (x 3)
10	Internal Hex Pan Head Bolt (x 6)	31	Engine Component
11	Clip Nut (x 10)	32	Hex Flange Bolt (x 2)
12	Damping Pad (x 2)	33	Cross Recessed Pan Head Self Tapping Screw (x 5)
13	Flat Washer (x 2)	34	Cooling Fan
14	Hex Flange Bolt (x 2)	35	Variable Frequency Motor Rotor
15	Clip Nut (x 6)	36	Hex Flange Nut
16	Hex Flange Nut (x 6)	37	Hex Flange Bolt (x 2)
17	Power Base Plate	38	Spring Washer (x 2)
18	Shock Absorber Seat (x 4)	39	Variable Frequency Motor Stator
19	Wheel Assembly (x 2)	40	Motor Cover
20	Wheel Axle (x 2)	41	Hex Flange Bolt (x 5)
21	Box Bottom Cushion	42	Positioning Pin Locking Clip (x 2)

43	Damper Cable	63	Hand Tighten Bolt
44	3 in 1 Switch Holder	64	Spring
45	Fuel Tank Switch	65	Rear Cover Plate Assembly
46	3 in 1 Switch Rotor	66	Spark Plug Repair Cover Plate
47	3 in 1 Switch Fixing Plate	67	Cross Recessed Pan Head Screw (x 2)
48	Cross Recessed Pan Head Self Tapping Screw (x 2)	68	Refueling Partition Pad
49	Door Cable Assembly	69	Machine Rear Shell Assembly
50	Protective Sleeve (550mm)	70	Cylinder Head Positioning Pad (x 2)
51	Gas Pipe	71	Fuel Tank Assembly
52	Hoop	72	Filter Screen Assembly
53	Fuel Tank Rubber Sleeve (x 4)	73	Clamp
54	Clamp	74	Fuel Pipe
55	Fuel Pipe	75	Clamp (x 2)
56	Sound Absorbing Cotton	76	Filter Screen
57	Motor Rubber Sleeve	77	Fuel Tank Cap
58	Silencer Outlet Cover Plate Assembly	78	Steel Wire Retaining Ring for Holes (x 5)
59	Positioning Pin (x 2)	79	Metal Wire Clamp (x 3)
60	Hex Flange Bolt (x 4)	80	Sealing Gasket
61	Plug	81	Rubber Sleeve (x 2)
62	Tie Rod Assembly	82	Spring Clip (x 6)

# DECLARATION OF CONFORMITY



## DECLARATION OF CONFORMITY

This is an important document and should be retained.

We hereby declare that this product(s) complies with the following legislation: The following standards have been applied to the product(s):

- Noise Emission in the Environment by Equipment for use Outdoors Regulations 2001 IEC 62321-4:2013+AMD1:2017, IEC 62321-7-1:2015, IEC 62321-5:2013, IEC 62321-6:2015,
- The Electromagnetic Compatibility Regulations 2016 EN IEC 61000-6-1:2019, EN ISO 8528-13:2016, EN ISO 17075-1:2017, IEC 62321-7-2:2017,
- The Supply of Machinery (Safety) Regulations 2008 EN ISO 3744:1995, ISO 8528-10:1998, IEC 62321-3-1:2013, IEC 62321-8:2017,
- The Non-Road Mobile Machinery (Type-Approval and Emission of Gaseous and Particulate Pollutants) Regulations 2018 EN 55012:2007+A1
- The Restriction of the Use of Certain Hazardous Substances in Electrical and Electronic Equipment Regulations 2012

The technical documentation required to demonstrate that the product(s) meet(s) the requirement(s) of the aforementioned legislation has been compiled and is available for inspection by the relevant enforcement authorities.

The UKCA mark was first applied in: 2024

<b>Manufacturer:</b>	Clarke International Ltd, Hemmell Street, Epping, Essex, CM16 4LG, United Kingdom	<b>Notified Body:</b>	TÜV Rheinland LGA Products GmbH (ID Number: 0197), Tillystraße 2, 90431 Nürnberg, Germany
<b>Product Description:</b>	Generator	<b>Assessment Procedure:</b>	Annex VI of above noise legislation
<b>Model Number(s):</b>	DFI1950	<b>Measured LWA:</b>	91.8 dB
<b>Serial/Batch Number:</b>	Refer to product/packaging label	<b>Guaranteed LWA:</b>	95 dB
<b>Document Holder:</b>	Alan Pond	<b>Signed:</b>	 A Clarke
<b>Date of Issue:</b>	18/12/2024		Director
DFI1950 UKCA Clarke DOC 121824			

# DECLARATION OF CONFORMITY



## DECLARATION OF CONFORMITY

This is an important document and should be retained.

We hereby declare that this product(s) complies with the following legislation: The following standards have been applied to the product(s):

2000/14/EC	Outdoor Noise Directive	IEC 62321-4:2013+AMD1:2017, IEC 62321-7-1:2015, IEC 62321-5:2013, IEC 62321-6:2015,
2014/30/EU	Electromagnetic Compatibility Directive	EN IEC 61000-6-1:2019, EN/ISO 8528-13:2016, EN/ISO 17075-1:2017, IEC 62321-7-2:2017,
2006/42/EC	Machinery Directive	EN ISO 3744:1995, ISO 8528-10:1998, IEC 62321-3-1:2013, IEC 62321-8:2017,
2016/1628	Particulate Emission and Type-Approval for Non-Road Mobile Machinery Regulation	EN 55012:2007+A1
2011/65/EU	Restriction of Hazardous Substances (RoHS) Directive	

The technical documentation required to demonstrate that the product(s) meet(s) the requirement(s) of the aforementioned legislation has been compiled and is available for inspection by the relevant enforcement authorities.

The CE mark was first applied in: 2024

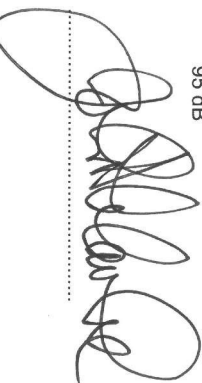
<b>Manufacturer:</b>	Clarke International Ltd, Fitzwilliam Hall, Fitzwilliam Place, Dublin 2, Republic of Ireland	<b>Notified Body:</b>	TÜV Rheinland LGA Products GmbH (ID Number: 0197), Tillystraße 2, 90431 Nürnberg, Germany
<b>Product Description:</b>	Generator	<b>Assessment Procedure:</b>	Annex VI of above noise legislation
<b>Model Number(s):</b>	DF11950	<b>Measured LWA:</b>	91,8 dB
<b>Serial/Batch Number:</b>	Refer to product/packageing label	<b>Guaranteed LWA:</b>	95 dB
<b>Document Holder:</b>	Alan Pond	<b>Signed:</b>	 J.A. Clarke Director
<b>Date of Issue:</b>	18/12/2024		
DF11950 CE Clarke DOC 121824			

# A SELECTION FROM THE VAST RANGE OF

# Clarke®

## QUALITY PRODUCTS



**AIR COMPRESSORS**  
From DIY to industrial, Plus air tools, spray guns and accessories.

**GENERATORS**  
Prime duty or emergency standby for business, home and leisure.

**POWER WASHERS**  
Hot and cold, electric and engine driven - we have what you need

**WELDERS**  
Mig, Arc, Tig and Spot. From DIY to auto/industrial.

**METALWORKING**  
Drills, grinders and saws for DIY and professional use.

**WOODWORKING**  
Saws, sanders, lathes, mortisers and dust extraction.

**HYDRAULICS**  
Cranes, body repair kits, transmission jacks for all types of workshop use.

**WATER PUMPS**  
Submersible, electric and engine driven for DIY, agriculture and industry.

**POWERTOOLS**  
Angle grinders, cordless drill sets, saws and sanders.

**STARTERS/CHARGERS**  
All sizes for car and commercial use.



## PARTS & SERVICE: 0208 988 7400

**Parts Enquiries**  
[Parts@clarkeinternational.com](mailto:Parts@clarkeinternational.com)

**Servicing & Technical Enquiries**  
[Service@clarkeinternational.com](mailto:Service@clarkeinternational.com)

SALES: UK 01992 565333 or Export 00 44 (0)1992 565335

**Clarke®** INTERNATIONAL Hemnall Street, Epping, Essex CM16 4LG  
[www.clarkeinternational.com](http://www.clarkeinternational.com)